

SPECIFICATION

MODEL: FH3XF-ZS

IP65 **CE** **RoHS**

UL[®]
C **US**
E491448

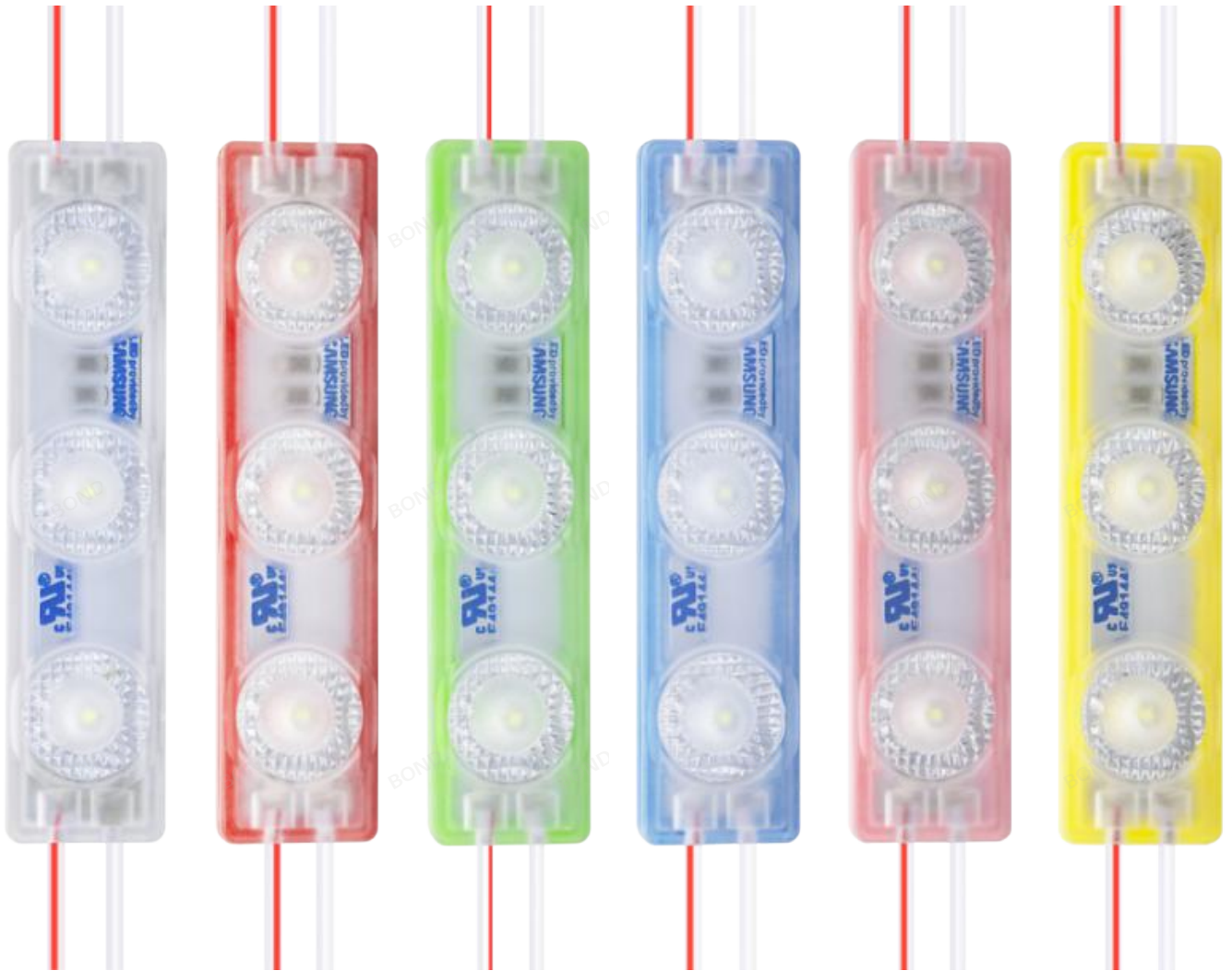

Feature:

- ◆ High light efficient 2835 SMD
- ◆ LED Low voltage DC 12V
- ◆ system synchronized color change,
- ◆ Waterproof tested IP65 tested
- ◆ Products through CE,RoHS Certification
- ◆ 3 years warranty

Dimension

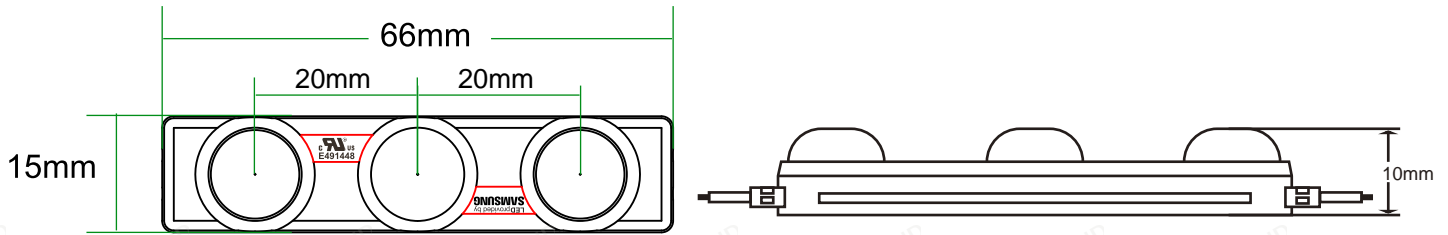

Specification



Item	Value	Unit
Color	WW/PW/CW/B/G/P/Y/R	-
Power Dissipation	1.5W	Watt
Forward Voltage	12	VDC
Forward Current	125	mA
Driving System	Constant Voltage	-
Luminous Flux	100-150	LM
CCT(K)	3000-12000	K
Wavelength(nm)	-	nm
CRI (Ra)	85	%
Viewing angle	170	deg
Module Pitch	90	mm
Size	65x15x8	mm
Weight	8	g
Max in series	20	EA
Operating Temp	-20~60	°C
Waterproof	IP65	
Life Time	3 years	L70
Cable	UL, 20AWG 300V/80°C	

Beaming Angle

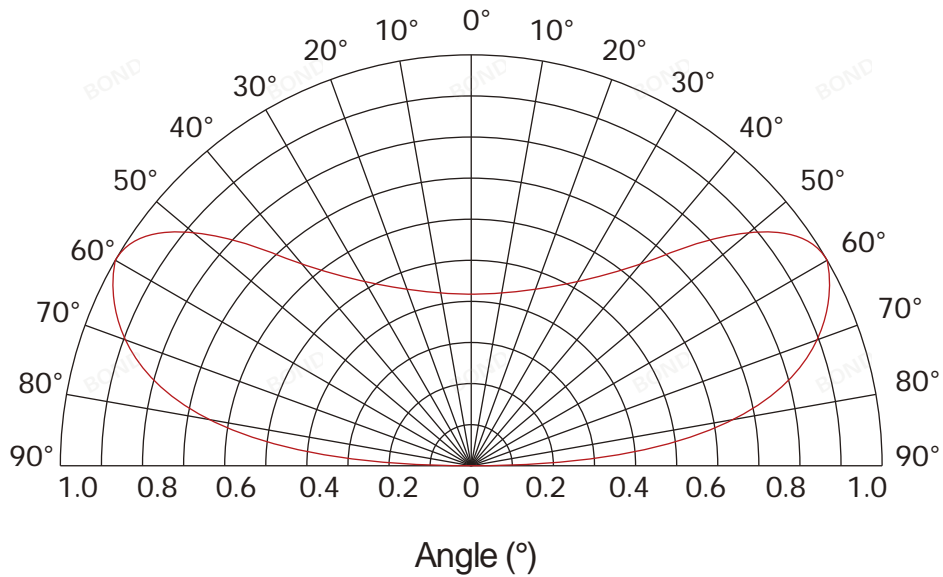

CIE Colorimetric Parameters

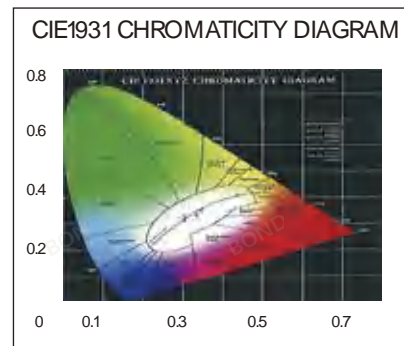
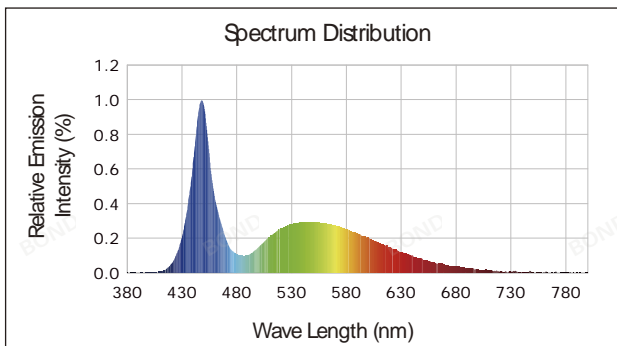

Package

Every 20 pcs per a string, every 5 string in colorful box packing, 2500pcs/ctn

Carton size: 50*35*35 cm.

Net Weight: 9 g/pc; 23kg/ctn



Application area



Connection Diagramm

AC 220V Input

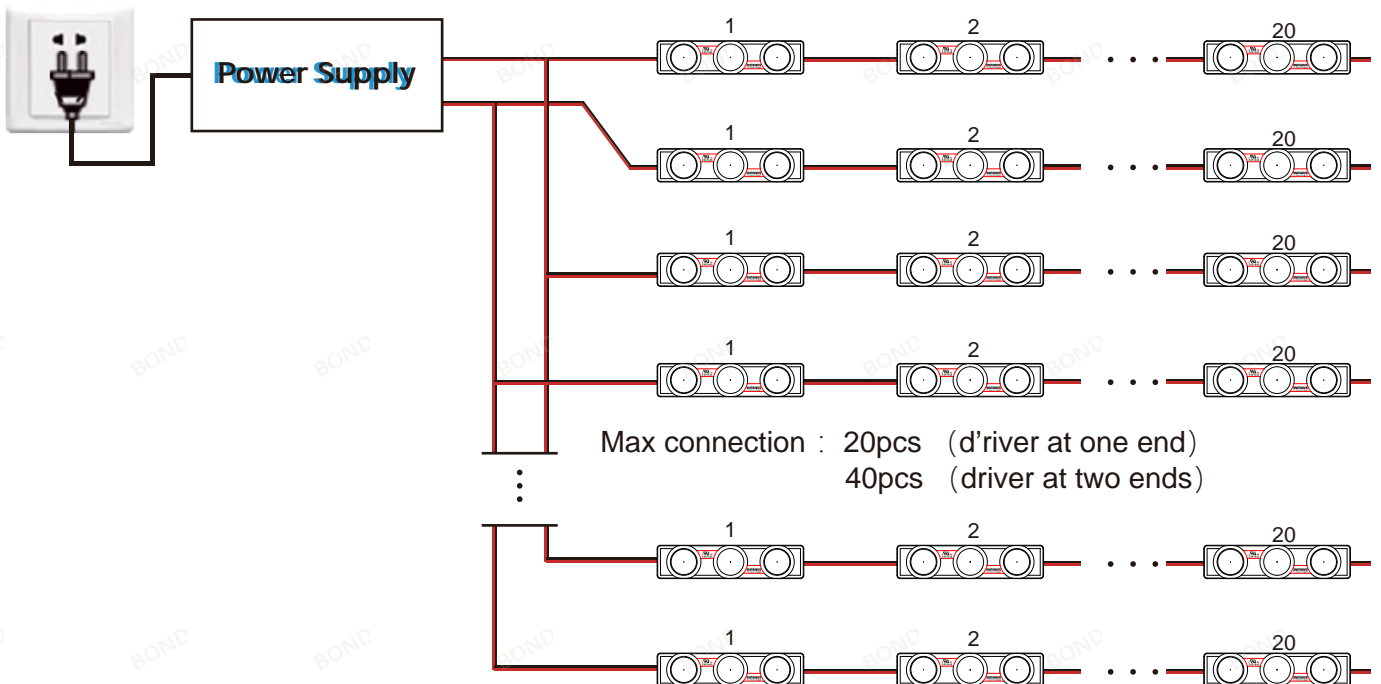

The number of standard modules per string can reach to 40pcs